



**Hawaiian
Electric**

TAP Schedule and Workplan

September 9, 2021

Agenda

TAP Purpose & Engagement

Current On-Going IGP Work

Tentative Stakeholder Technical Working Group Schedule

TAP Structure & Composition

TAP Review & Stakeholder Feedback Process

TAP Schedule



TAP Purpose

Independent technical peer (“Red Team”) review of IGP methods, tools & analysis

- PUC Guidance*: “...*provide independent review of each review point filing that the Companies will file.*”

Technical subject matter experts providing input/feedback on selected nearer-term and longer-term issues as identified by IGP SC, STWG, Commission & HECO

* HPUC Order No. 36725



TAP Engagement

Objectives:

- ◆ Improve TAP effectiveness
- ◆ Increase TAP Transparency & Stakeholder Understanding

Key areas for continuous improvement:

- ◆ TAP composition, meeting structure and discussion materials
- ◆ TAP communications & interface with stakeholder groups
- ◆ Broaden scope of topics to include both nearer and longer-term considerations relevant to Hawaii to inform decision-making



TAP Engagement

TAP will schedule regular meetings with the standing members

- ◆ Meeting topics will be coordinated with the TAP Chair
- ◆ Efforts will be made to provide discussion materials at least 1 week in advance
- ◆ Meeting discussions will be conducted under Chatham House Rules
- ◆ Summary meeting notes will be prepared by Hawaiian Electric for review by the TAP Chair and members

TAP may include ad hoc subject experts as desired to address selected issues identified by the Stakeholder Council, Stakeholder Technical WG, Commission and/or Hawaiian Electric

- ◆ TAP Chair will coordinate with Hawaiian Electric to identify and invite experts to participate on an ad hoc basis

TAP members and selected ad hoc experts may be requested to develop technical papers on selected topics to inform stakeholders and Commission (funding as needed may be available)

TAP discussion summaries and any work products (e.g., Red Team reviews, topic papers, etc.) will be adapted by Hawaiian Electric with TAP review, as needed, for general audiences to support broader stakeholder understanding



Work in progress for next Review Point

- ◆ **Update circuit level hosting capacity needs for DER integration (high/low scenarios)**
- ◆ **Locational DER and load forecasts (LoadSEER)**
 - Provide qualitative and quantitative summaries of LoadSEER findings and disaggregated location-specific load forecasts;
 - Demonstrate how the probabilistic forecasts developed with LoadSEER will inform the different reference case load forecast scenarios to be established using the "bookends" approach;
- ◆ **Transmission Renewable Energy Zones Analysis (REZ)**
- ◆ **Review of modeling methods, planning criteria and grid service rules with the TAP**
 - Review of inertia, FFR, regulating reserve, ERM
 - Better explain and analytically support its grid services and planning criteria
 - Whether system balancing and ancillary service rules are clear and justified
- ◆ **ERM Testing (RESOLVE and PLEXOS)**
 - 40%, 30%, 20%, 10%, 0% target; Replace HDC with production profiles
 - HNEI Probabilistic Assessment
- ◆ **Energy Efficiency Supply Curves (AEG)**



Tentative Stakeholder Meeting Schedule

STWG 9/7

- ◆ Review Inputs & Assumptions
- ◆ First Draft EE Supply Curves (AEG)
- ◆ Workplan for Oct 1 filing, IGP sched update

STWG 9/23

- ◆ TOU Adoption Evaluation for Non-DER/-EV customers
- ◆ Final EE Supply Curve Meeting (AEG)

STWG Week of 10/4

- ◆ Circuit Hosting Capacity and Locational Forecasts
- ◆ REZ Assessment
- ◆ System Security Process; Expected deliverables

STWG Week of 10/11

- ◆ ERM Analysis
- ◆ HNEI Probabilistic Assessment

STWG TBD, if needed

- ◆ Review changes incorporated based on stakeholder feedback



Distribution Sub-Group

- ◆ Distribution Planning Criteria, Process, Methods and Tools, Services (NWA Framework)

Transmission Sub-Group

- ◆ Review Transmission Planning Criteria and System Security Scope (stability services)
- ◆ Renewable Energy Zone

Resource Adequacy and Modeling Sub-Group

- ◆ Review ERM Testing and Reg. Reserve requirements
- ◆ Review Preliminary RESOLVE 'Bookends' (Later)

Sub-group leads to work with HECO SMEs/POCs

- ◆ Topics to discuss and review
- ◆ Develop schedule for review/deliverables

Leads report findings back to the broader TAP

- ◆ Chair/Vice-Chair report high level findings to Stakeholder Council

Follow-up with Commission Staff on expected form and content of TAP reviews.

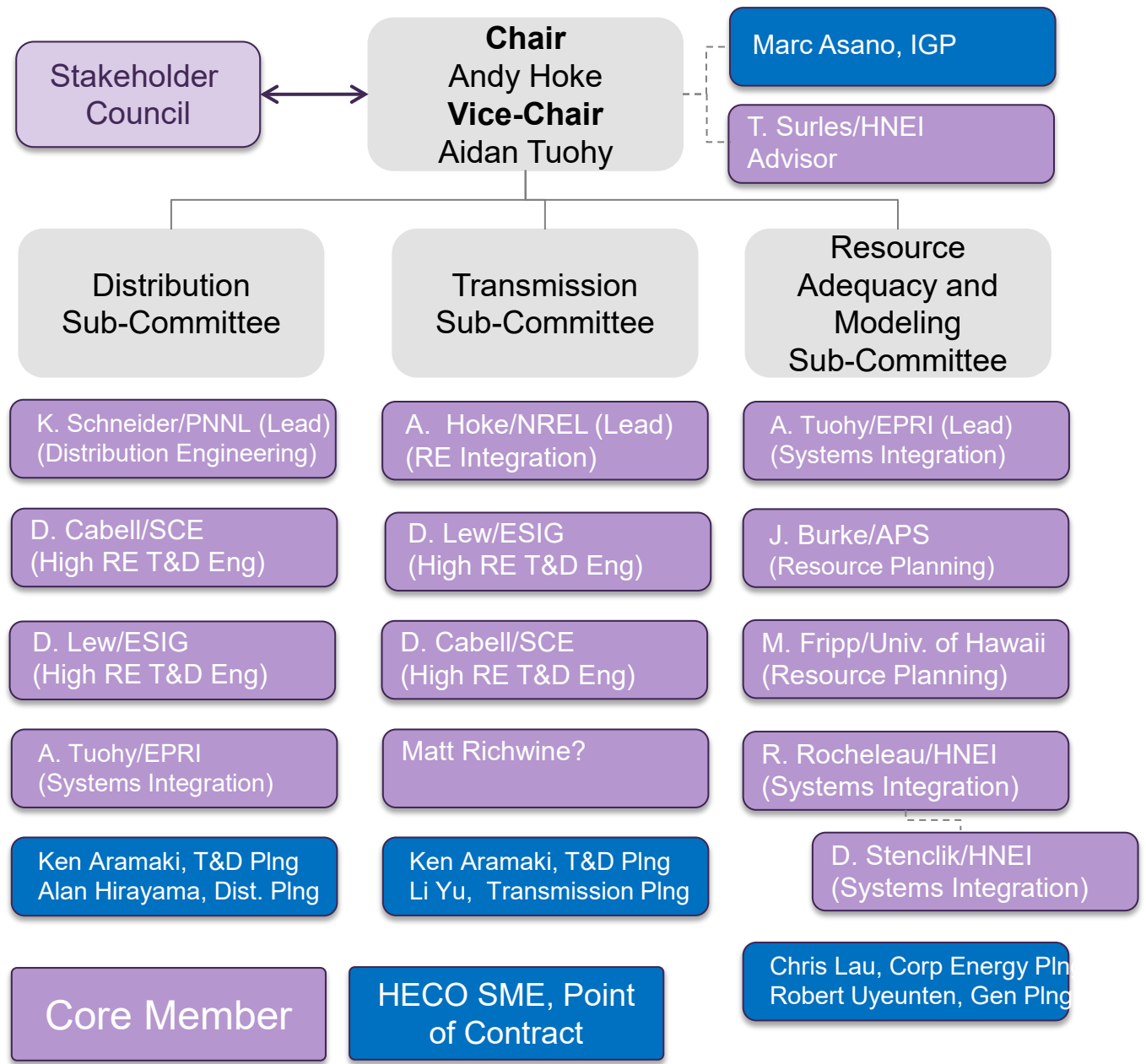

TAP Review & Stakeholder Feedback Process

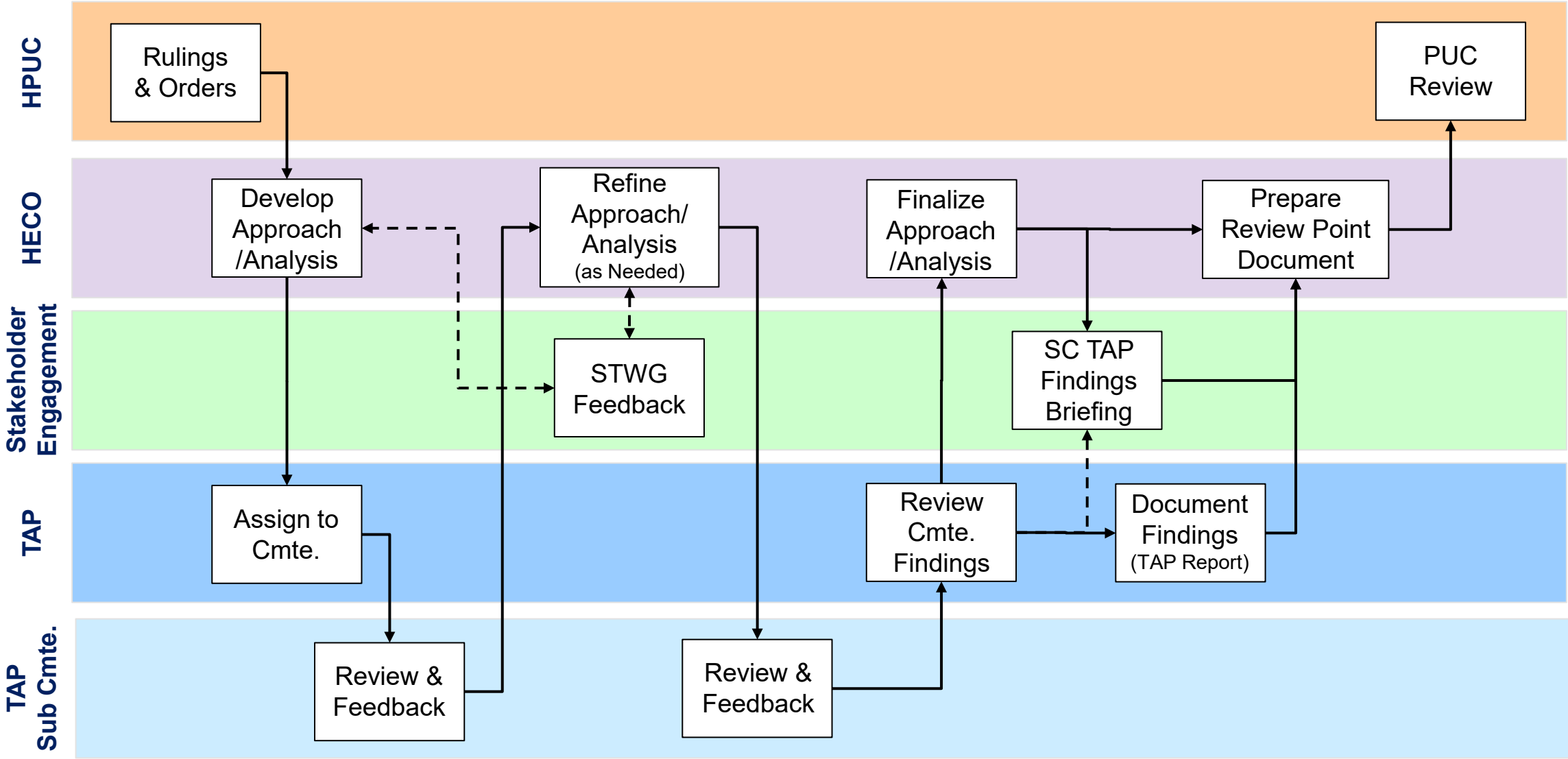

Upcoming TAP Schedule

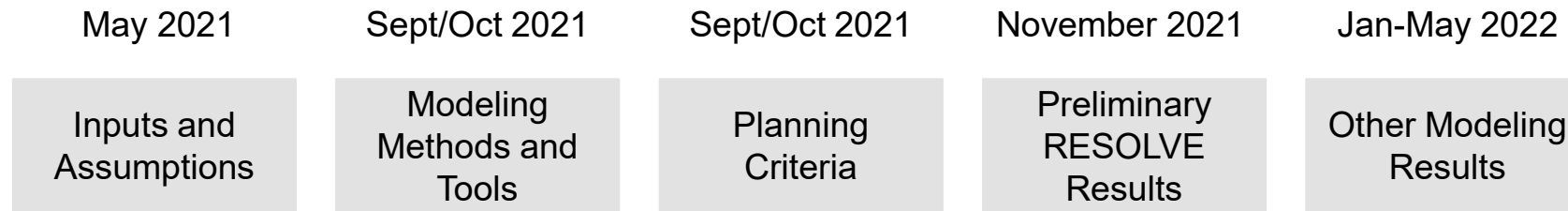

See Previous Slide for topics

Schedule Sub-Committee meetings.

- ◆ With pre-read materials estimate two 2-3 hour sub-committee meetings?
- ◆ TAP Leads/Hawaiian Electric to determine depth of review in meetings and/or if meetings are required for a particular topic
- ◆ TAP's Independent Review Report of findings and recommendations
- ◆ ACTION: Update the PUC with a high-level schedule of TAP activities and the scope of the deliverables



Questions?



